

TBE-130 & 165 Upright Mixer



Economic Lightweight Mixer

- The builder's choice for portability and safety
- Loads or tips either side for fast operation
 - Barrow height discharge
 - Easy to maintain
 - Electric
- CE compliant, with NVR (No Volt Return) safety power switch
- Extra light weight vertical mixers, easily maneuverable
- Compact design



www.BelleGroup.com

No.1 for Light Construction Equipment

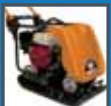

COMPACTING...

MIXING...

CONCRETING...

CUTTING...

BREAKING...

MOVING

Economic light weight mixer, used by DIY or semi-professionals. These upright mixers use a proven motor and gear system to provide reliable mixing.

Technical Specifications

Model		TBE 130
Part Number		MU27
Voltage	(V)	230
Motor Power	(Hp/kW)	0.6/0.45
Current	(Amp)	2.2
Power Consumption	(w)	450
Frequency	(Hz)	50
Protective System		IP44
Motor RPM		2800
A - Width	(mm)	790
B - Height	(mm)	1230
C - Length	(mm)	1160
Drum Volume	(ltr)	130
Mixing Output	(ltr)	80
Drum Speed	(rpm)	29
Weight	(kg)	50
Noise Level	(dB(A))	90



Model		TBE 165
Part Number		MU28
Voltage	(V)	230
Motor Power	(Hp/kW)	0.6/0.45
Current	(Amp)	2.2
Power Consumption	(w)	450
Frequency	(Hz)	50
Protective System		IP44
Motor RPM		2800
A - Width	(mm)	790
B - Height	(mm)	1295
C - Length	(mm)	1160
Drum Volume	(ltr)	165
Mixing Output	(ltr)	100
Drum Speed	(rpm)	29
Weight	(kg)	53
Noise Level	(dB(A))	90

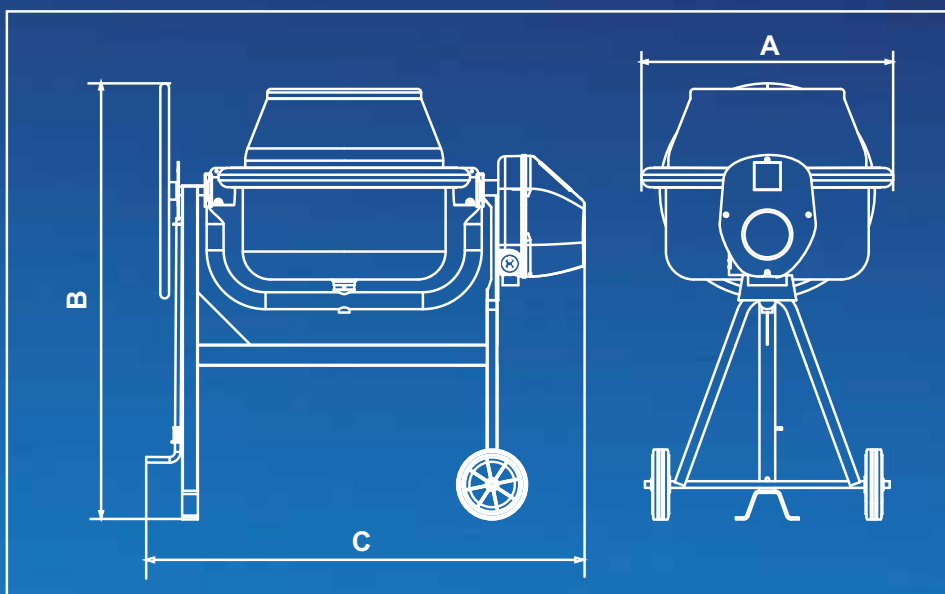

Belle Group Head Office
Sheen, Nr. Buxton
Derbyshire, SK17 0EU
Tel: (+44) 01298 84606
Fax: (+44) 01298 84722
Email: sales@belle-group.co.uk

Dealer Stamp:

www.BelleGroup.com

Belle Group reserve the right to amend or improve any specifications in this brochure without notice.